

MEGA-COUPPLING

Series 3800

Restrained Coupling

The Series 3800 Restrained Coupling is used for joining and restraining two plain end pipes of the same or dissimilar materials (Ductile Iron Pipe, Steel Pipe, PVC Pipe (C900 or ASTM D2241) and/or High Density Polyethylene Pipe (HDPE)). This device provides axial restraint to the rated pressure listed below, with a minimum factor of safety of 2:1. The Series 3800 is an economical alternative to the harnessing of unrestrained repair type couplings.



Image depicts Series 3806 on 6 inch ductile iron pipe and 6 inch PVC pipe.

Features and Applications:

- For use on:
 - Ductile Iron Pipe
 - Steel Pipe
 - PVC Pipe (C900 or ASTM D2241)
 - High Density Polyethylene Pipe (HDPE)
- Sizes 4 inch through 12 inch
- Minimum 2 to 1 Safety Factor
- **MEGA-BOND®** Restraint Coating System
For more information regarding MEGA-BOND, refer to our web site @ www.ebaa.com
- Constructed of ASTM A536 Ductile Iron
- Corrosion Resistant, low alloy, high strength steel bolts and nuts per ANSI/AWWA C111/A21.11
- Couplings meets or exceeds the applicable requirements of:
 - AWWA C219
 - ASTM A536
 - ANSI/AWWA C111/A21.11
 - ASTM D2000
- For use on water or wastewater pipelines subject to hydrostatic pressure and tested in accordance with either AWWA C600 or ASTM D2774.

Nominal Pipe Size	Series Number	Approximate Shipping Weight	Ductile Iron Pipe	Steel Pipe	Pressure Ratings (PSI)					
					HDPE Pipe			C900 PVC Pipe		
					DR11 Class 160	DR13.5 Class 130	DR17 Class 100	DR14 Class 200	DR18 Class 150	DR25 Class 100
4	3804	36.50	250	250	160	130	100	200	150	100
6	3806	49.40	250	250	160	130	100	200	150	100
8	3808	67.93	250	250	160	130	100	200	150	100
10	3810	85.46	250	250	160	130	100	200	150	100
12	3812	103.98	250	250	160	130	100	200	150	100

The Series 3800 are designed to restrain forces based on the maximum working pressure ratings listed above.

Forces experienced due to expansion/contraction of the pipe require special consideration.

Special Notes For Use On HDPE Pipe

The use of a pipe wall stiffening insert is required for use on HDPE pipe.

The stiffeners must be sized to encompass the entire bearing length of the restraint devices. Pipe systems must be engineered to prevent movement causing fitting to slide or rotate.

EBA products for HDPE are designed for underground pressurized fluid service and are pressure rated to match the pipe SDR pressure rating, de-rated as appropriate for service temperature. Maximum test pressure limited to pipe rated pressure.

Series 3800 Submittal Reference Drawing

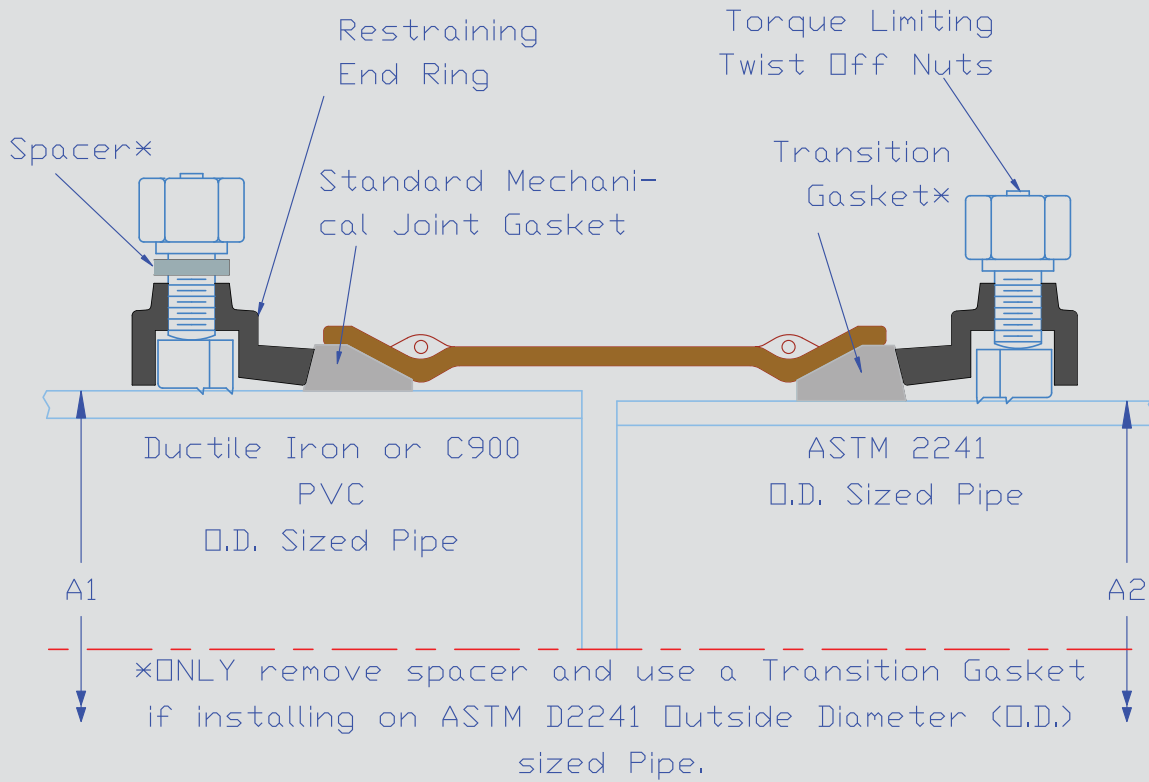

EBAA IRON

MADE IN USA

Nominal Pipe Size	Series Number	A1 Pipe O.D. (Maximum)	A2** Pipe O.D. (Minimum)	B Overall Length	C*** Max. Restraint O.D. (Casing Clearance)	D Thrust Bolt (Number-Size)	E Barrel Length	Maximum Deflection
4	3804	4.80	4.50	14.0	9.5	4 - 3/4 x 14	7.5	5°
6	3806	6.90	6.63	14.0	12.1	6 - 3/4 x 14	7.5	5°
8	3808	9.05	8.63	14.0	13.6	6 - 3/4 x 14	7.5	5°
10	3810	11.10	10.75	14.0	16.0	8 - 3/4 x 14	7.5	5°
12	3812	13.20	12.75	14.0	18.1	8 - 3/4 x 14	7.5	5°

Series 3800 Submittal Reference Drawing

** Requires the use of a Transition Gasket.

*** As installed with Twist-Off nuts off.

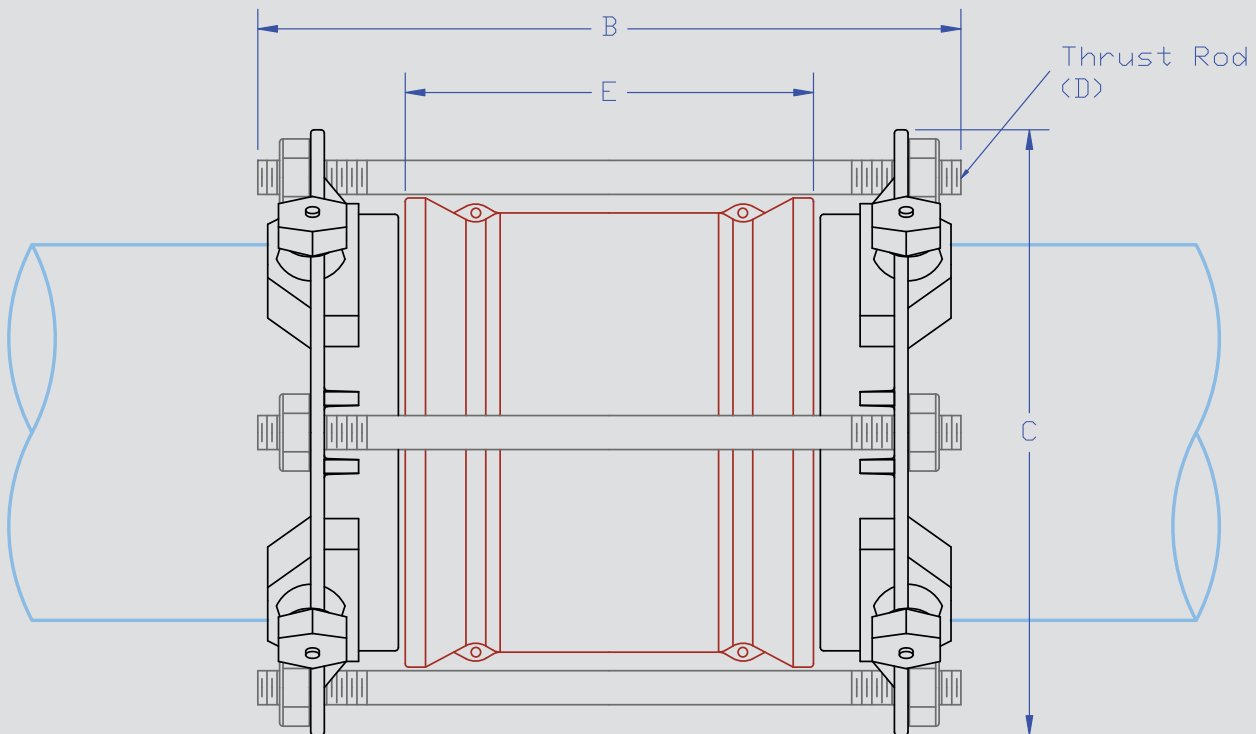

MADE IN USA

EBAA IRON

Note: Dimensions are in inches and are subject to change without notice.

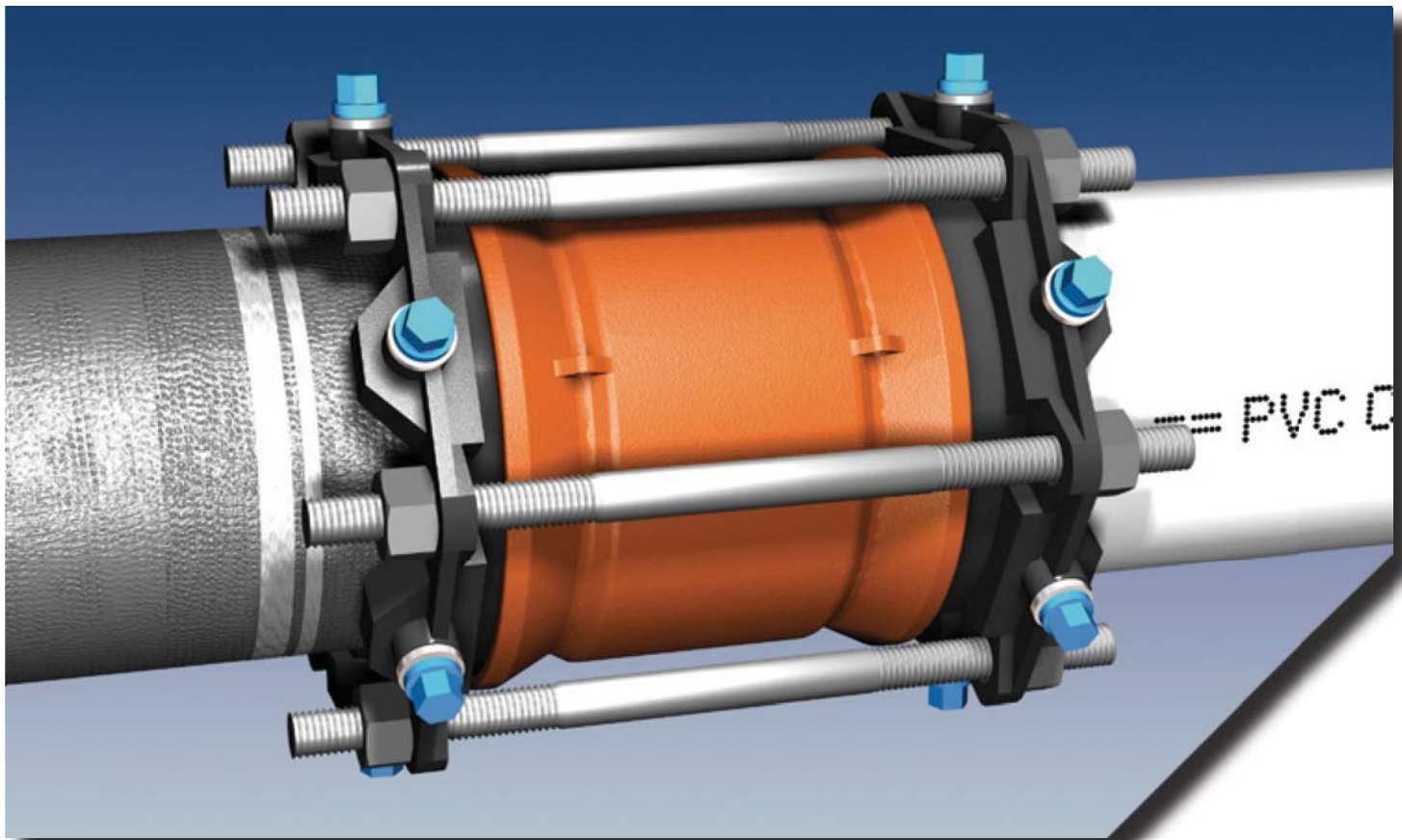

Gripping Wedge

The gripping wedge works along the same principle as EBAA Iron, Inc.'s Series 1100 MEGALUG® and Series 2000PV MEGALUG® gripping wedges. Once set to the proper torque by the Twist-Off Nuts, the wedge then evenly “grips” the pipe preventing axial movement. The “grip” strength grows as the thrust grows allowing for a truly dynamic restraint.

Torque Limiting Twist-Off Nuts

The Twist-Off Nuts, which were designed and developed by the engineers of EBAA Iron, Inc., are specifically made to “twist-off” at the correct ft.-lbs of torque. This allows for proper installation and eliminates the need for expensive torque wrenches, which can become cumbersome in field application. Accommodation for ASTM D2241 PVC and Steel pipes are made by simply unscrewing of the wedge actuating screws, removing the spacer, and then replacing the wedge actuating screws.

Coating of Coupling and Restraints

The Sleeve is coated with a fusion bonded epoxy to give long term corrosion protection, and is NSF61 Approved for potable water contact. The coating is applied to a minimum of 15 mils and is Holiday tested with a 1500 V spark test in accordance to ANSI/AWWA C213.

The Restraints are coated with EBAA's MEGA-BOND™ Restraint Coating System. This incorporates a polyester based powder coat on restraints and a flouropolymer coating on all wedges and related parts.

Sample Specification

Joint restraint to prevent axial separation shall be incorporated into the design of the sleeve or coupling used to connect two plain ends of same or dissimilar materials, such as ductile Iron pipe, steel pipe, PVC pipe (C900 or ASTM D2241) and or High Density Polyethylene (HDPE) pipe. Internal pipe wall stiffeners must be used when restraining HDPE.

The restraint mechanism shall incorporate a plurality of individually actuating gripping surfaces to maximize restraint capability, and have torque limiting twist off nuts to insure proper actuating of the restraint devices such as the Series 2000HPV MEGALUG®.

The restraint devices shall be coated using MEGA-BOND™, for complete specifications on MEGA-BOND visit www.ebaa.com.

The coupling sleeve internal surfaces (wetted parts) shall be lined with a minimum of 15 mils of fusion bonded epoxy conforming to the applicable requirements of ANSI/AWWA C213. Sealing gaskets shall be constructed of EPDM. The coating and gaskets shall meet ANSI/NSF-61. Exterior surfaces shall be coated with a minimum of 6 mils of fusion bonded epoxy conforming to the applicable requirements of ANSI/AWWA C116/A21.16. Ductile Iron components shall meet or exceed the requirements of ASTM A536, and shall be tested in accordance with said standard.

The restrained joining system shall meet the applicable requirements of AWWA C219, ANSI/AWWA C111/A21.11, and ASTM D2000.

The restrained coupling system shall be Series 3800 manufactured by EBAA Iron, Inc. or an approved equal.

Spacer Instructions

Ductile Iron or C900 PVC O.D. Sized Pipe

For installation on **Ductile Iron** or **C900 PVC sized pipe**, use as received and install per instructions.

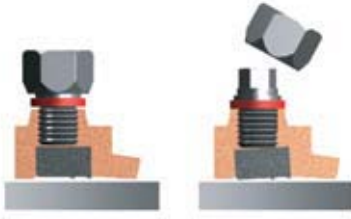

Steel or ASTM D2241 O.D. Sized Pipe (IPS O.D.)

For installation on **Steel** or **ASTM D2241 O.D. Sized pipe**, remove spacers and replace screws. Install per instructions.



Installation Instructions

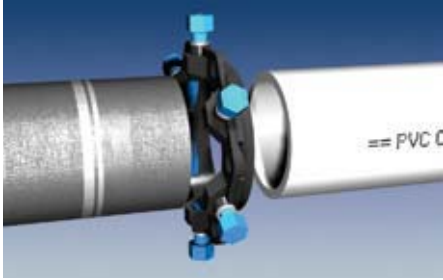

1. Identify the pipe. The spacers under the actuating screws must be removed for use on ASTM D2241 O.D. sized pipe. The spacers must remain in place for use on Ductile Iron or C900 PVC O.D. sized pipe. (see spacer instructions above) Clean and inspect the pipe ends. Beveling of the ends is not necessary.

If used on HDPE Pipe, a pipe wall stiffener insert that encompass the entire bearing length of the restraint devices must be installed prior to step 2.

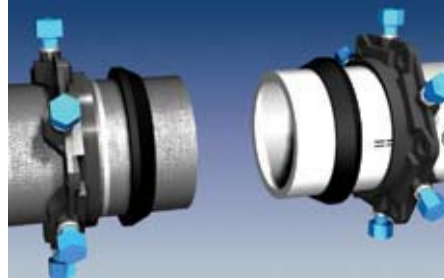

2. Place the end rings on the pipes with the lip extensions toward the pipe ends. Lubricate and install the Standard Mechanical Joint Gasket. (Standard Mechanical Joint Gaskets must be used with Ductile Iron Pipe and C900 PVC pipe. Transition gaskets must be used with Steel or ASTM D2241 pipe).



3. Center the sleeve body over the ends of the pipes while maintaining a 1/2" to 1" gap between the pipe ends. Slide the gaskets and end rings toward the sleeve body.

Distributors:
Power Plant Supply Co
Ontario, Canada 416 752 3339
Atlantic, Canada 902 435 9899
www.powerplantsupplyco.com
info@powerplantsupplyco.com



4. Install the threaded rods and hand tighten the nuts on each end.

Gradually tighten the nuts in an alternating manner to 60-75 ft. lbs. while maintaining the same distance between the rings and the ends of the body at all points around the rings.



5. Hand tighten the actuating screws until all wedges are touching the pipes. Continue tightening the screws in an alternating manner until the torque limiting heads twist off. The screws may bottom out during this step.

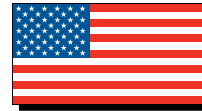

EBAA IRON Sales, Inc.
P.O. Box 857, Eastland, TX 76448
Tel: (254) 629-1731
Fax: (254) 629-8931
(800) 433-1716 within US and Canada
contact@ebaa.com
www.ebaa.com